



**UTILITY
BEDLOCKER™**
Electric Retractable Tonneau cover
for Utility Truck Beds

by



PACE EDWARDS WILL CUSTOM FIT ANY UTILITY TRUCK BED

Please fill out the dimensions below and fax back to us at (360) 736-9992

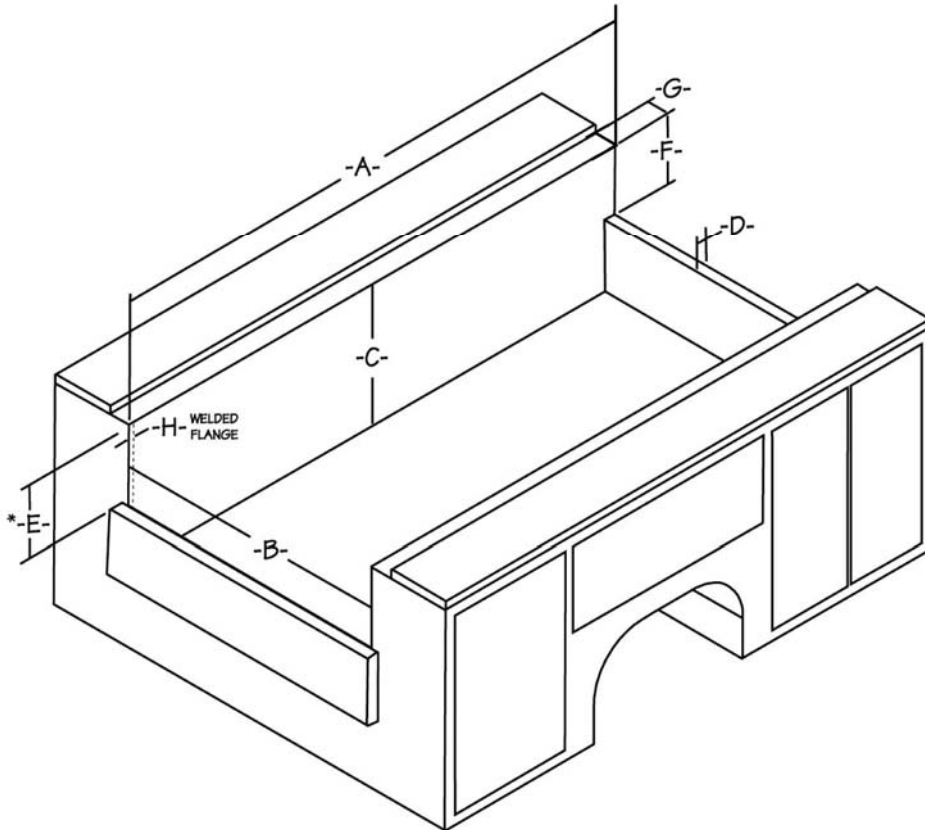

A	
B - FRONT	
REAR	
C	
D	
E	
F	
G	
H	

NOTES:

1. MAKE ALL MEASUREMENTS IN INCHES WITH DIMENSIONS ACCURATE TO WITHIN 1/16TH OF AN INCH
 2. BOX MATERIAL THICKNESS IN DECIMAL OR FRACTION
- * MEASUREMENTS TO INCLUDE CLEARANCE FOR ANY WELD BEADS AROUND TAILGATE LATCHES

TAILGATE STYLE: (CHECK ONE)

HOOK _____ SLAMGATE _____
LIFT&LATCH _____

UTILITY BED:

MAKE _____
MODEL _____ YEAR _____

CONTACT INFORMATION

Name _____

Address _____

City _____ State/ Prov _____ Zip _____

Phone _____ Fax _____

Application Guide and Jobber pricing

UTILITY BEDLOCKER™ WITH ANODIZED ALUMINUM EXPLORER SERIES™ RAILS

Bed Length	Standard Part #	List Price
8'	UBLXXXXXX	Call for Price!
9'	UBLXXXXXX	Call for Price!
11'	UBLXXXXXX	Coming soon!



800.338.3697 • 360.736.9992 (fax) • 2400 Commercial Blvd. • Centralia, WA 98531

Part # UBJP 0704 Web